

BIJA Industrie®

Aerospace & Industry

TEMPORARY FASTENERS

www.bija-industrie.com

✉ contact@bija-industrie.com

☎ +33 (0)608 963 932

📠 +33 (0)494 725 805



Fasteners 1000 SERIES

LISI AEROSPACE



Manually operated fasteners
installation tool
Ref : 50.1000.05



Pneumatic pliers:
Supply: lubricated air, pressure 6 bar



Réf PPA-013-D
Straight version

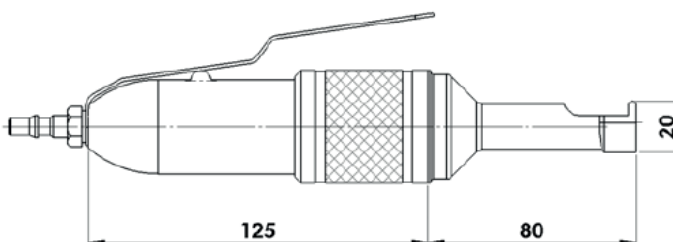

Réf PPA-013-E
90° angle version

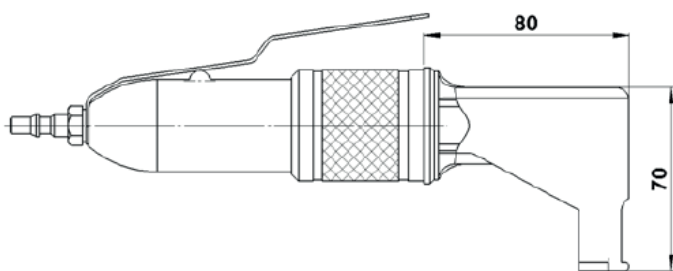

Réf PPA-013-O
105° inclined version

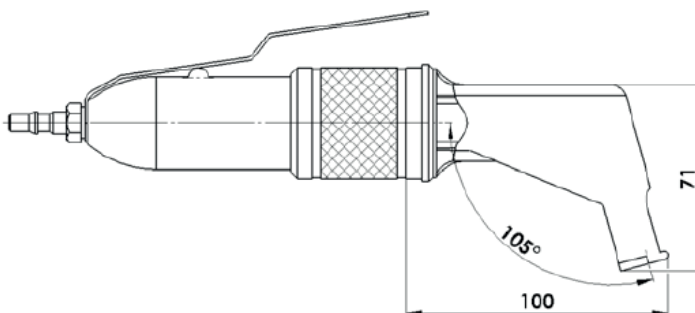



Fasteners 1000 SERIES

LISI AEROSPACE

PRESENTATION :

- **Features:** This push-pull fastener allows quick and easy installation using simple tools on assemblies that do not require high preloads: maximum clamping force 20 daN.
- **Dimensional:** Diameters, colors and clamping capacities are defined in the table below.
- **Weight:** Kg/1000 pieces = 8 Kg.

Dimensions en mm



1000 Series



1000 Series

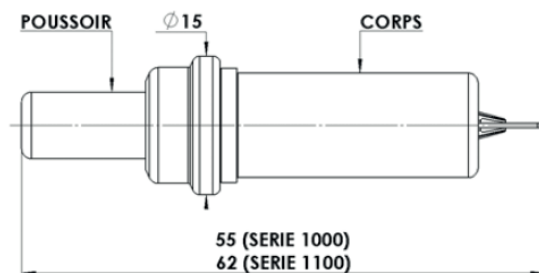

Couleur du corps plastique	Ø de perçage	
	Série 1000	Série 1100
Jaune	2,0	-
Rouge	2,4 / 2,5	2,4 / 2,5
Marron	3,0	3,0
Gris	3,2	3,2
Vert	3,5 / 3,6	3,5 / 3,6
Bleu	4,0	4,0
Blanc	4,8	4,8

Couleur du poussoir plastique	Rouge	Blanc
Capacité de serrage	0 - 6,5	6,5 - 13



IN STOCK

Red	1024/25	
Grey	1032	
Blue	1040	
White	1048	

Codification example:

10 - 32

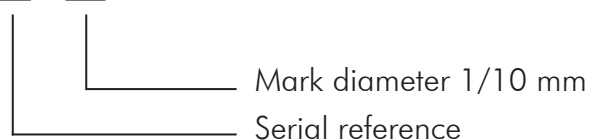



Screwdrivers 41 SERIES

LISI AEROSPACE

PRESENTATION :

- Automatic shut-off by air cut driver.
- High precision clamping.
- The torque in response is taken up by the hex of the fastener body.
- The nose of the screwdriver allows the extraction of the fastener by performing a rotation of 1/12th of a turn. In addition to the standard screwdrivers referenced in the table, special installation tools are available on request (reduced dimensions, motor manufacturers ...)

Straight screwdriver

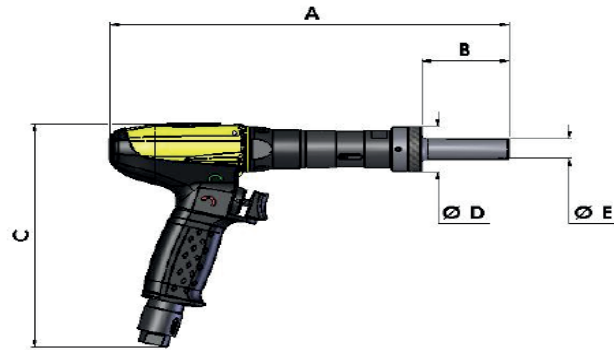

Référence	Couple	A (mm)	B (mm)	C (mm)	Ø D (mm)	Ø E (mm)
VPA 75 27 D1 10	0,6 à 4 N.m	296	82	184	35	19,5
VPA 75 37 D1 10	3,5 à 10 N.m	319	82	184	35	19,5

90° angle screwdriver

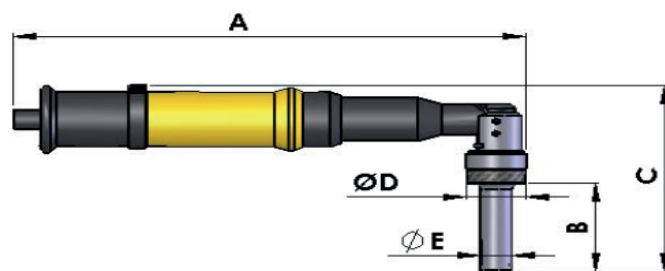

Référence	Couple	A (mm)	B (mm)	C (mm)	Ø D (mm)	Ø E (mm)
VPA 41 17 E1 10	0,5 à 3 N.m	258	73,0	128	29	16,5
VPA 41 07 E1 10	2,5 à 7 N.m	357	73	130	29	16,5

Codification example:

VPA 75 27 D 1 - 10



- Hex value of the nut
- Order number
- Straight (D) or 90° (E)
- Range
- Fastener series
- Screwdriver for fastener



Screwdrivers 41 SERIES

LISI AEROSPACE

PRESENTATION :

- **Features:** Temporary fastener with double threaded stem is intended for fast installation and removal. These high-performance spring-loaded fasteners are designed for assemblies with interposition sealant, special anti-adhesive treatment is provided. It thus prevents the fastener from being clogged by the sealing products used in the assemblies.
- **Dimensional:** Diamètres, couleurs et capacité de serrage sont définis dans le tableau ci-dessous.
- Dispositif de contrôle des efforts installés. Réf: ACP-040.
- **Weight:** Kg/1000 pieces = 39 Kg.

Dimensions in mm

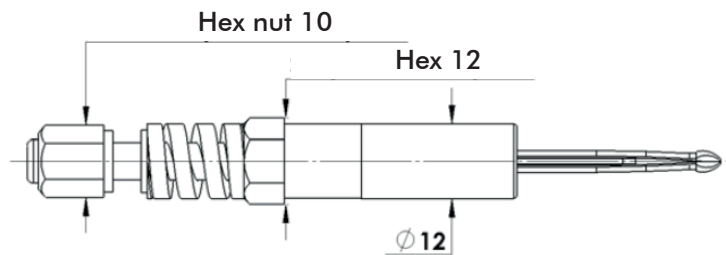

Ø nominal	Ø de perçage	Couleur du corps plastique	Capacité de serrage	Force de serrage maxi (daN)	Ø nominal	Ø de perçage	Couleur du corps plastique	Capacité de serrage	Force de serrage maxi (daN)
2,4	2,4-2,5	Noir	00-15 00-25	100	5,0	5H7	Jaune	00-15 00-25 15-40	350
3,0	3-3,1	Noir	00-15 00-25	100	5,6	5,4-5,7	Noir	00-15 00-25 15-40 25-50	350
3,2	3,2-3,35	Rouge	00-15 00-25 10-35	200	5,8	5,7-6	Vert	00-15 00-25 15-40 25-50	350
3,6	3,5-3,7	Bleu	00-15 00-25 10-35	200	6,0	6H7	Vert	00-15 00-25 15-40 25-50	350
4,1	4-4,2	Blanc	00-15 00-25 15-40	250	6,3	6,2-6,5	Marron	00-15 00-25 15-40 25-50	350
4,8	4,7-5	Jaune	00-15 00-25 15-40 25-50	350					

Codification example:

41 - 32 - 00 - 25

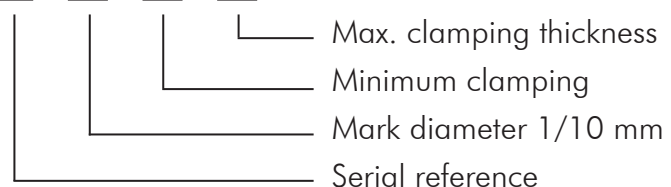

IN STOCK

- Black 4124-00-15
- Red 4132-00-15
- White 4141-00-15
- Yellow 4148-00-15