

BIJA Industrie®

Aerospace & Industry

ASSEMBLY
CUTTING
TOOLS



COUNTERSINKS WITH PILOT HSS

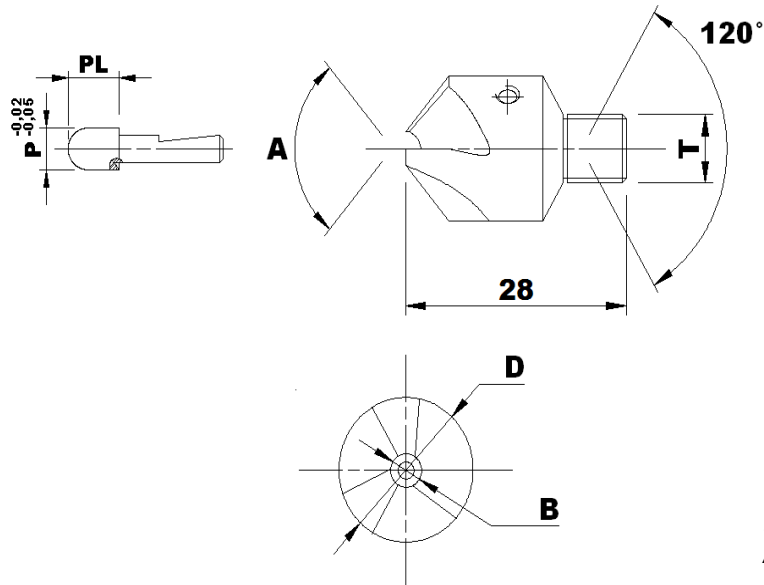

For:
Aluminium, (Titanium)

Reference	D	P	Flutes nber	Thread (T)
FH200	10	2.00	2	M6x100
FH238	10	2.38	2	M6x100
FH240	10	2.40	2	M6x100
FH250	10	2.50	2	M6x100
FH280	10	2.80	2	M6x100
FH300	10	3.00	2	M6x100
FH317	10	3.17	2	M6x100
FH320	10	3.20	2	M6x100
FH350	10	3.50	2	M6x100
FH400	10	4.00	2	M6x100
FH415	10	4.15	2	M6x100
FH476	14	4.76	2	M8x100
FH480	14	4.80	2	M8x100
FH500	14	5.00	2	M8x100
FH560	14	5.60	2	M8x100
FH600	14	6.00	2	M8x100
FH635	14	6.35	2	M8x100
FH794	17	7.94	3	M8x100
FH800	17	8.00	3	M8x100
FH952	21	9.52	3	M8x100
FH100	21	10.00	3	M8x100

COUNTERSINKS WITH PILOT CARBIDE

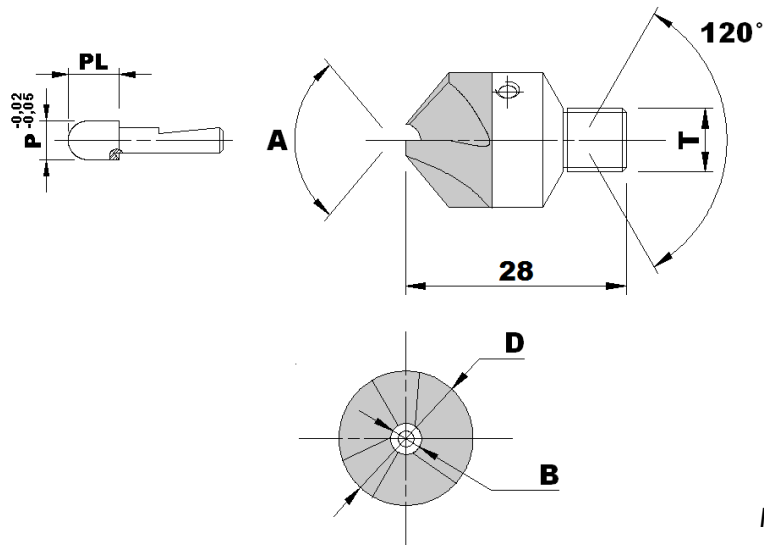

For:
Aluminium,
Titanium, (Composite)

Reference	D	P	Flutes nber	Thread (T)
FC200	10	2.00	2	M6x100
FC238	10	2.38	2	M6x100
FC240	10	2.40	2	M6x100
FC250	10	2.50	2	M6x100
FC280	10	2.80	2	M6x100
FC300	10	3.00	2	M6x100
FC317	10	3.17	2	M6x100
FC320	10	3.20	2	M6x100
FC350	10	3.50	2	M6x100
FC400	10	4.00	2	M6x100
FC415	10	4.15	2	M6x100
FC476	14	4.76	2	M8x100
FC480	14	4.80	2	M8x100
FC500	14	5.00	2	M8x100
FC560	14	5.60	2	M8x100
FC600	14	6.00	2	M8x100
FC635	14	6.35	2	M8x100
FC794	17	7.94	3	M8x100
FC800	17	8.00	3	M8x100
FC952	21	9.52	3	M8x100
FH100	21	10.00	3	M8x100

COUNTERSINKS WITH PILOT PCD

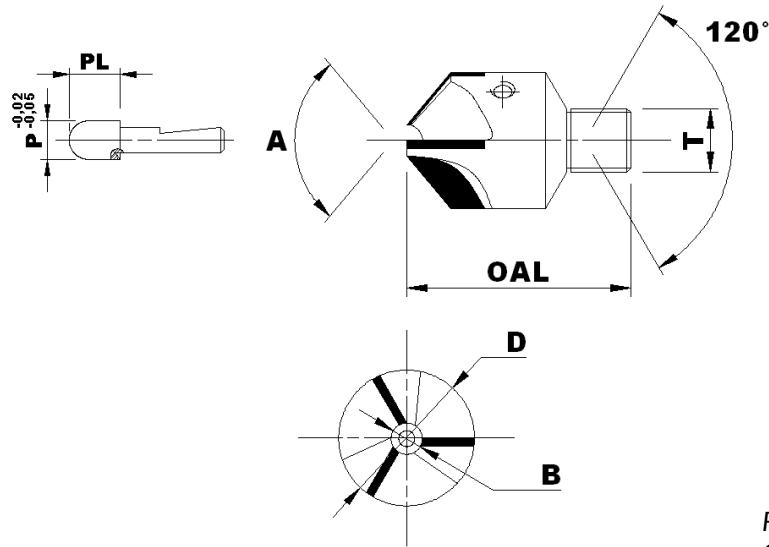

For:
Composite, CFRP

Reference	D	P	Flutes nber	Thread (T)
FP200	10	2.00	2	M6x100
FP238	10	2.38	2	M6x100
FP240	10	2.40	2	M6x100
FP250	10	2.50	2	M6x100
FP280	10	2.80	2	M6x100
FP300	10	3.00	2	M6x100
FP317	10	3.17	2	M6x100
FP320	10	3.20	2	M6x100
FP350	10	3.50	2	M6x100
FP400	10	4.00	2	M6x100
FP415	10	4.15	2	M6x100
FP476	14	4.76	2	M8x100
FP480	14	4.80	2	M8x100
FP500	14	5.00	2	M8x100
FP560	14	5.60	2	M8x100
FP600	14	6.00	2	M8x100
FP635	14	6.35	2	M8x100
FP794	17	7.94	3	M8x100
FP800	17	8.00	3	M8x100
FP952	21	9.52	3	M8x100
FP100	21	10.00	3	M8x100

DAGGER DRILLS CARBIDE

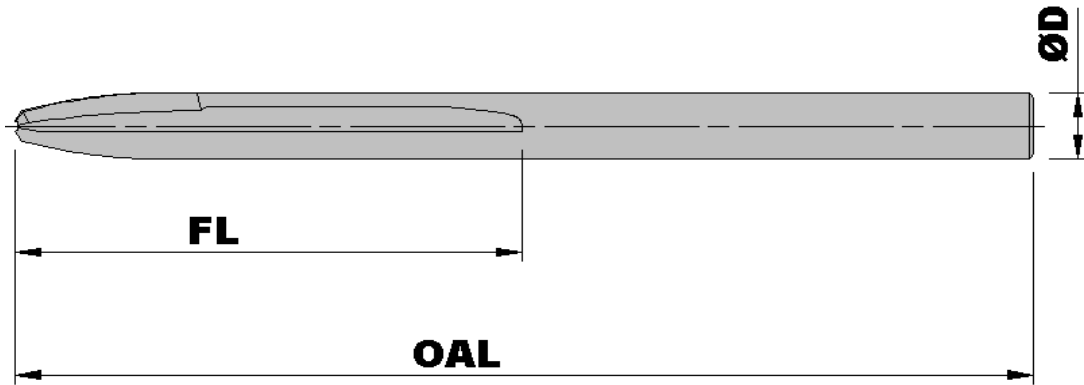

Reference	D	FL	Flutes nber	OAL
DC250	2.50	50	3	100
DC317	3.17	50	3	100
DC330	3.30	50	3	100
DC400	4.00	50	3	100
DC410	4.10	50	3	100
DC413	4.13	50	3	100
DC416	4.16	50	3	100
DC420	4.20	50	3	100
DC480	4.80	50	3	100
DC481	4.81	50	3	100
DC482	4.82	50	3	100
DC494	4.94	50	3	100
DC510	5.10	50	3	100
DC600	6.00	50	3	100
DC620	6.20	50	3	100
DC650	6.50	50	3	100

HONEYCOMB MILLS

HSS

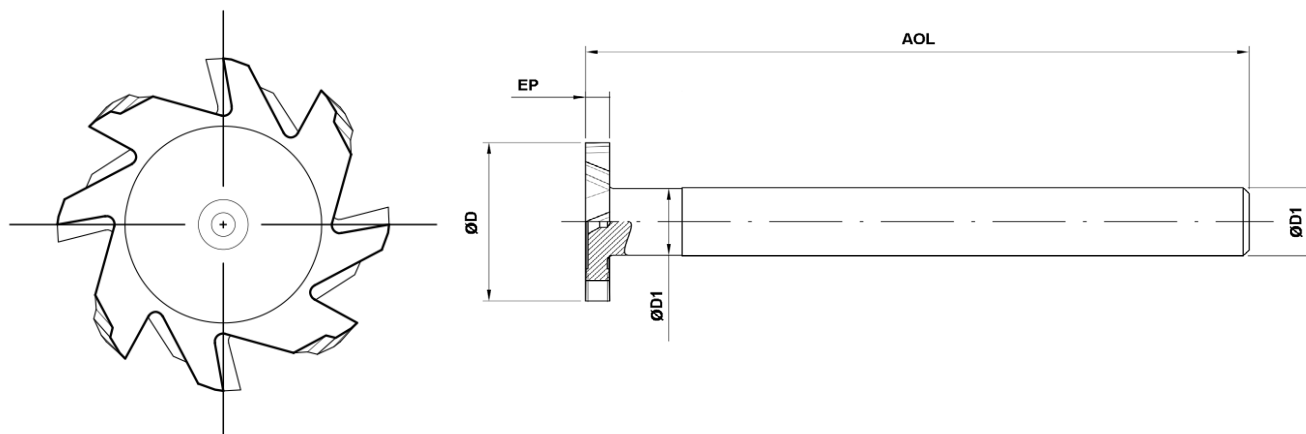

Reference	D	D1	EP	OAL
NY09	9.00	6.00	2.00	55
NY10	10.00	6.00	2.00	55
NY11	11.00	6.00	2.00	55
NY12	12.00	6.00	2.00	55
NY13	13.00	6.00	2.00	55
NY14	14.00	6.00	2.00	55
NY15	15.00	6.00	2.00	55
NY16	16.00	6.00	2.00	55
NY17	17.00	6.00	2.00	55
NY18	18.00	6.00	2.00	55
NY19	19.00	6.00	2.00	55
NY20	20.00	6.00	2.00	55
NY25	25.00	6.00	2.00	55
Diameter, thickness and length can be custom-made				

TREPANS WITH PILOT CARBURE

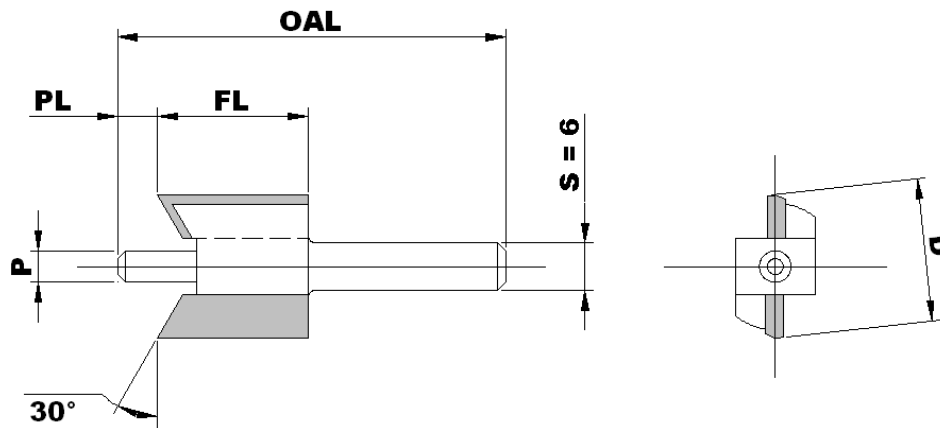

Reference	D	FL	P	OAL
TPC100	10.00	15	4.00	45
TPC105	10.50	15	4.00	45
TPC110	11.00	15	4.00	45
TPC112	11.20	15	4.00	45
TPC115	11.50	15	4.00	45
TPC120	12.00	15	4.00	45
TPC125	12.50	15	4.00	45
TPC127	12.70	25	4.00	55
TPC130	13.00	25	4.00	55
TPC140	14.00	25	4.00	55
TPC142	14.20	25	4.00	55
TPC150	15.00	25	4.00	55
TPC160	16.00	25	4.00	55
TPC162	16.20	25	4.00	55
TPC164	16.40	25	4.00	55
TPC174	17.40	25	4.00	55
TPC180	18.00	25	4.00	55
TPC190	19.00	25	4.00	55
TPC200	20.00	25	4.00	55
TPC210	21.00	25	4.00	55
TPC220	22.00	25	4.00	55
TPC230	23.00	25	4.00	55
TPC240	24.00	25	4.00	55
TPC250	25.00	25	4.00	55

BONDING BRUSHES STAINLESS STEEL WIRE

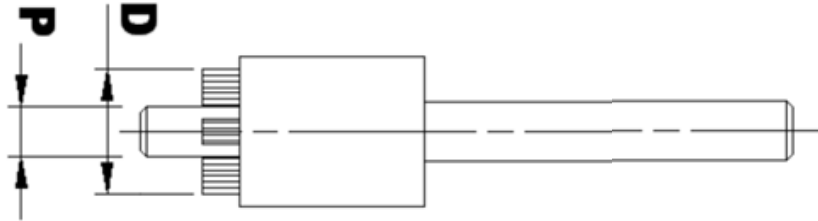

ACCORDING TO STANDARD ECA3113 & ECA-L 3113
BONDING BRUSHES RULE IFMA 527-35

Reference	Ø Brush	Ø Pilot	Washer standard	Series
BMP-SP06/21	6.00	2.10	EN2139 EN2138	Standard Series
BMP-SP07/26	7.00	2.60		
BMP-SP08/31	8.00	3.10		
BMP-SP10/41	10.00	4.10		
BMP-SP12/47	12.00	4.70		
BMP-SP12/51	12.00	5.10		
BMP-SP14/61	14.00	6.10		
BMP-SP16/71	16.00	7.10		
BMP-SP18/81	18.00	8.10		
BMPB-LSP14/41	14.00	4.10		
BMPB-LSP18/51	18.00	5.10		
BMPB-LSP20/61	20.00	6.10		
BMPB-LSP24/81	24.00	8.10		
BMPB-LSP32/101	32.00	10.10		
BMPB-LSP24/95	24.00	9.50		
BMPB-LSP24/120	24.00	12.00		
BMPB-MSP14/51	14.00	5.10	-	Mass Module
BMPB-LSP26/81	26.00	8.10	-	Anti-vibration

HOLE CUTTER KIT

HCK12M



7 Cutters

5/16» - 3/8» - 7/16» - 1/2» - 9/16» - 5/8» - 3/4»

1 Arbor Assembly

2 Pilots

3 Adjusting Wrenches

1 Center Punch

CUTTING DRILLS

Reference	Designation
B-FDCZ2	Ø3 HSS-Co8 2 flutes
B-FDCZ3	Ø3 HSS-Co8 3 flutes



ADAPTERS TOOLS

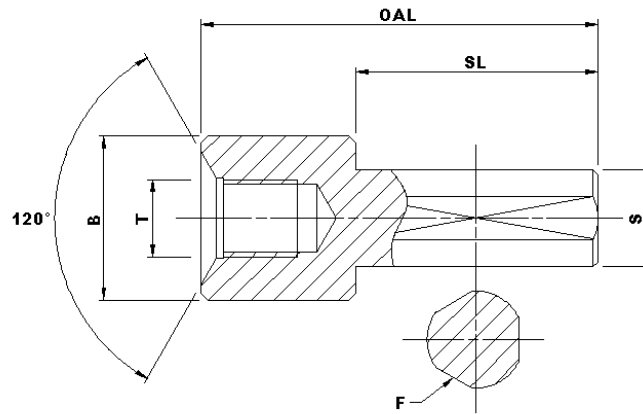

Reference	Thread (T)	S	SL	OAL
AD4M6	M6x100	4.00	15	30
AD6M6	M6x100	6.00	20	50
AD8M6L	M6x100	8.00	20	96
AD6M8	M8x100	6.00	20	50
AD8M8	M8x100	6.00	20	50
AD8M8L	M8x100	8.00	20	96
AD10M10	M10x100	10.00	20	50

MICROSTOPS

- BMF6S** - M6x100 - Safety base
- BMF6S-N** - With black identification ring
- BMF6S-B** - With blue identification ring
- BMF6S-R** - With red identification ring
- BMF6S-V** - With green identification ring



- BMF8S** - M8x100 - Safety base
- BMF8S-N** - With black identification ring
- BMF8S-B** - With blue identification ring
- BMF8S-R** - With red identification ring
- BMF8S-V** - With green identification ring



F.O.D CASES



Countersinks & Microstops



Countersinks & Pilots for back countersinks

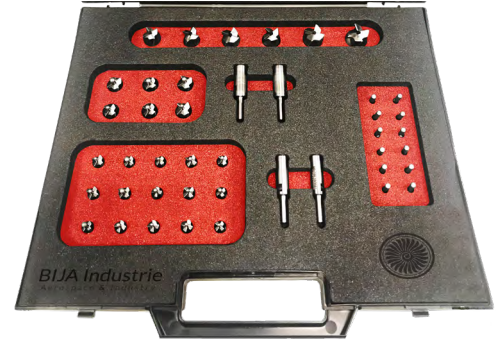

Counterbores & Pilots for counterbores

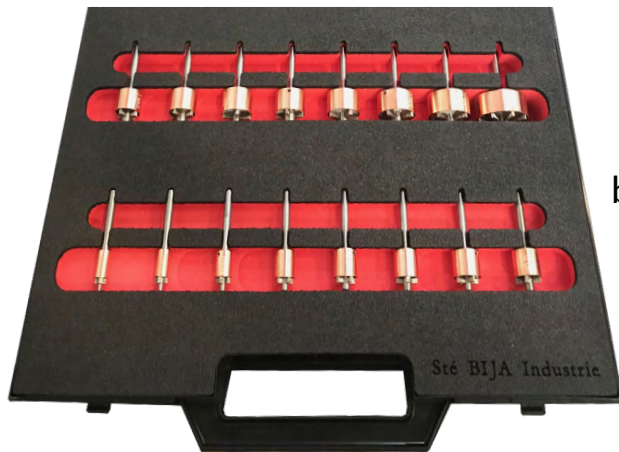

Forth & Back bonding brushes

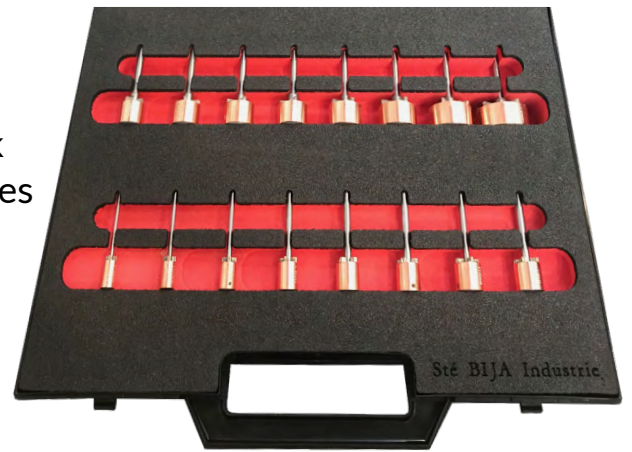

Reamers \varnothing 1.00 -> \varnothing 5.90
Reamers \varnothing 5.90 -> \varnothing 10.0



HSS trepans
 \varnothing 10.0 -> \varnothing 50.0

BIJA Industrie®

Aerospace & Industry



WWW.BIJA-INDUSTRIE.COM

✉ contact@bija-industrie.com

☎ +33 (0)494 725 805

B I
J A
LB Group